

REV.	ECN.	DATE	DWN	APVD

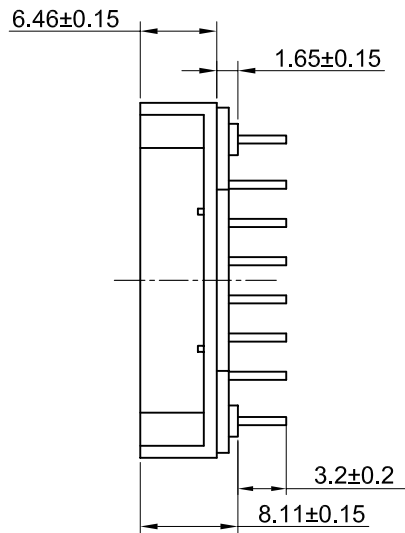
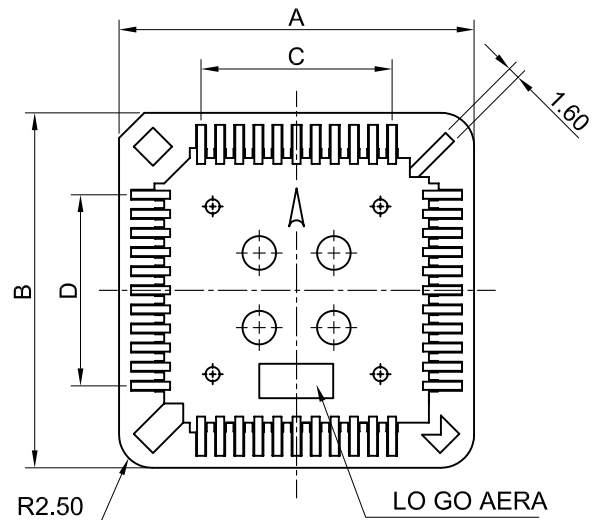

MATERIAL:

INSULATOR : PBT + 40% GLASS FIBER (UL 94V-0).
 CONTACT : PHOSPHOR BRONZE.
 CONTACT FINISH : TIN OVER NICKEL PLATED.

SPECIFICATION:

CURRENT RATING:1A.
 DIELECTRIC WITHSTANDING VOLTAGE : 500V AC FOR 1 MINUTE.
 INSULATION RESISTANCE : 1000MΩ MIN.
 CONTACT RESISTANCE : 30mΩ MAX.
 OPERATING TEMPERATURE : -55°C ~ +105°C.

ORDER INFORMATION :

SP11 - 44 2 T 1 B 0 1 - R
 1 2 3 4 5 6 7 8 9

- | | |
|---|---------------------------------------|
| 1. SERIES NUMBER | 7. OPTION:
0=STANDARD TYPE |
| 2. POSITION:
20 28 32 44 52 68 84 | 8. PACKING METHOD:
1=TUBE |
| 3. CONTACT MATERIAL:
2=PHOSPHOR BRONZE | 9. GREEN PRODUCT:
R=RoHS COMPLIANT |
| 4. CONTACT PLATING:
T=TIN | |
| 5. INSULATOR COLOR:
1=BLACK | |
| 6. INSULATOR MATERIAL:
B=PB | |

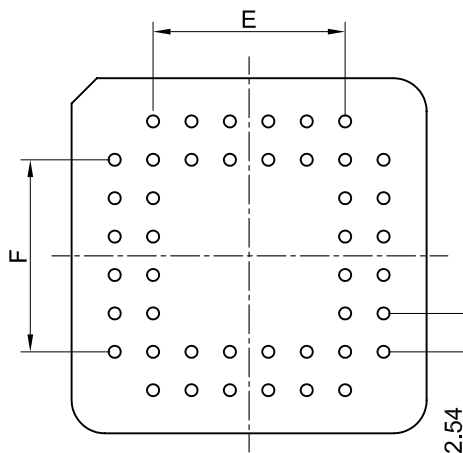

PCB LAYOUT

POSITION	A±0.15	B±0.15	C±0.15	D±0.15	E±0.15	F±0.15
20	15.50	15.50	5.08	5.08	5.08	5.08
28	18.04	18.04	7.62	7.62	7.62	7.62
32	18.04	20.54	7.62	10.16	10.16	10.16
44	23.48	23.48	12.70	12.70	12.70	12.70
52	25.88	25.88	15.24	15.24	15.24	15.24
68	31.66	31.66	20.32	20.32	20.32	20.32
84	36.66	36.66	25.40	25.40	25.40	25.40

維鼎股份有限公司
WEKANG CO., LTD.
 TEL:886-2-26436301 FAX:886-2-26432714

SIZE A4	UNIT mm	SCALE 2 / 1	SHEET 1 OF 1
------------	------------	----------------	-----------------

GENERAL TOLERANCE
 X.X ± 0.25
 X.XX ± 0.15
 X.XXX ± 0.05
 ANGLE TOLERANCE ± 1°
 RADIUS ± 0.25
 HOLE ± 0.13

DRAWN. TRACY	DATE 09 - 20 - 2006	DRAWING NO. SP11-XX2T1B01-R	C08025
CHECKED. FIONA HSU	DATE 10 - 19 - 2006	TITLE. PLCC SOCKET DIP TYPE	
APPROVED. 徐德和	DATE 10 - 19 - 2006	PART NO. SP11-XX2T1B01-R	REV A.0

REV.	ECN.	DATE	DWN	APVD

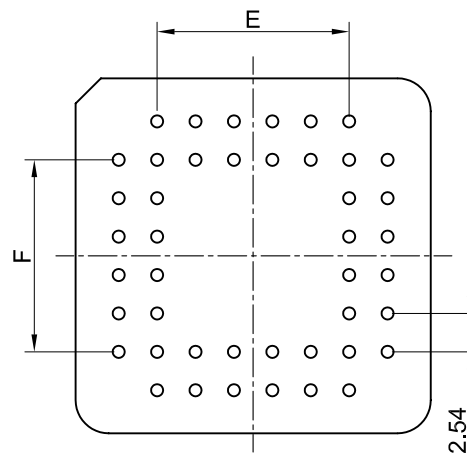
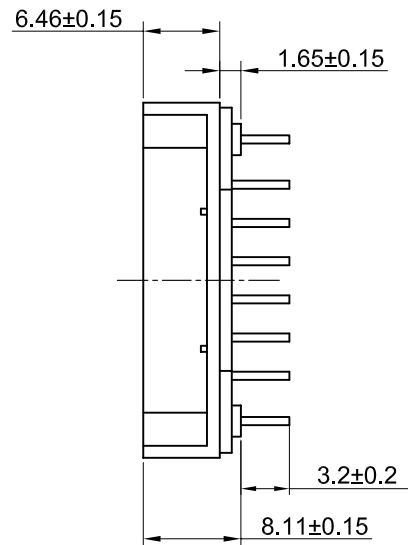
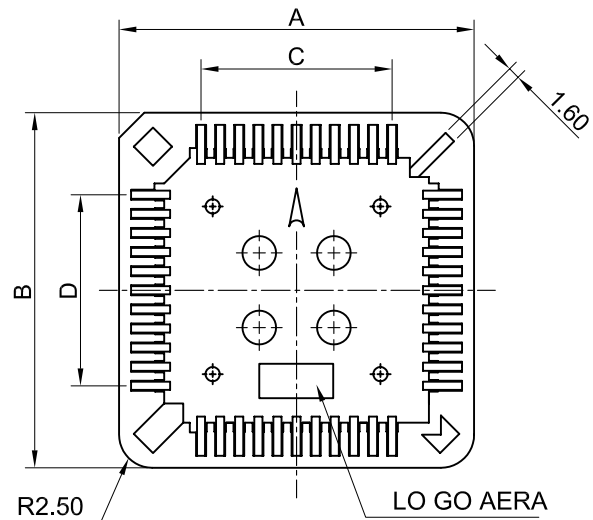

PCB LAYOUT

MATERIAL:

INSULATOR : PPS (UL 94V-0).
 CONTACT : PHOSPHOR BRONZE.
 CONTACT FINISH : TIN OVER NICKEL PLATED.

SPECIFICATION:

CURRENT RATING:1A.
 DIELECTRIC WITHSTANDING VOLTAGE : 500V AC FOR 1 MINUTE.
 INSULATION RESISTANCE : 1000MΩ MIN.
 CONTACT RESISTANCE : 30mΩ MAX.
 OPERATING TEMPERATURE : -55°C ~ +105°C.

ORDER INFORMATION :

S P 1 1 - 4 4 2 T 1 D 0 1 - R
 1 2 3 4 5 6 7 8 9

- | | |
|---|---------------------------------------|
| 1. SERIES NUMBER | 7. OPTION:
0=STANDARD TYPE |
| 2. POSITION:
20 28 32 44 52 68 84 | 8. PACKING METHOD:
1=TUBE |
| 3. CONTACT MATERIAL:
2=PHOSPHOR BRONZE | 9. GREEN PRODUCT:
R=RoHS COMPLIANT |
| 4. CONTACT PLATING:
T=TIN | |
| 5. INSULATOR COLOR:
2=BROWN | |
| 6. INSULATOR MATERIAL:
D=PPS | |

POSITION	A±0.15	B±0.15	C±0.15	D±0.15	E±0.15	F±0.15
20	15.50	15.50	5.08	5.08	5.08	5.08
28	18.04	18.04	7.62	7.62	7.62	7.62
32	18.04	20.54	7.62	10.16	10.16	10.16
44	23.48	23.48	12.70	12.70	12.70	12.70
52	25.88	25.88	15.24	15.24	15.24	15.24
68	31.04	31.04	20.32	20.32	20.32	20.32
84	36.04	36.04	25.40	25.40	25.40	25.40

維鼎股份有限公司
WEKANG CO., LTD.
 TEL:886-2-26436301 FAX:886-2-26432714

SIZE A4	UNIT mm	SCALE 2 / 1	SHEET 1 OF 1
------------	------------	----------------	-----------------

GENERAL TOLERANCE
 X.X ± 0.25
 X.XX ± 0.15
 X.XXX ± 0.05
 ANGLE TOLERANCE ± 1°
 RADIUS ± 0.25
 HOLE ± 0.13

DRAWN. TRACY	DATE 09 - 20 - 2006	DRAWING NO. SP11-XX2T2D01-R	C08025
CHECKED. FIONA HSU	DATE 10 - 19 - 2006	TITLE. PLCC SOCKET DIP TYPE	
APPROVED. 徐德和	DATE 10 - 19 - 2006	PART NO. SP11-XX2T2D01-R	REV A.0