

REV.	ECN.	DATE	DWN	APVD

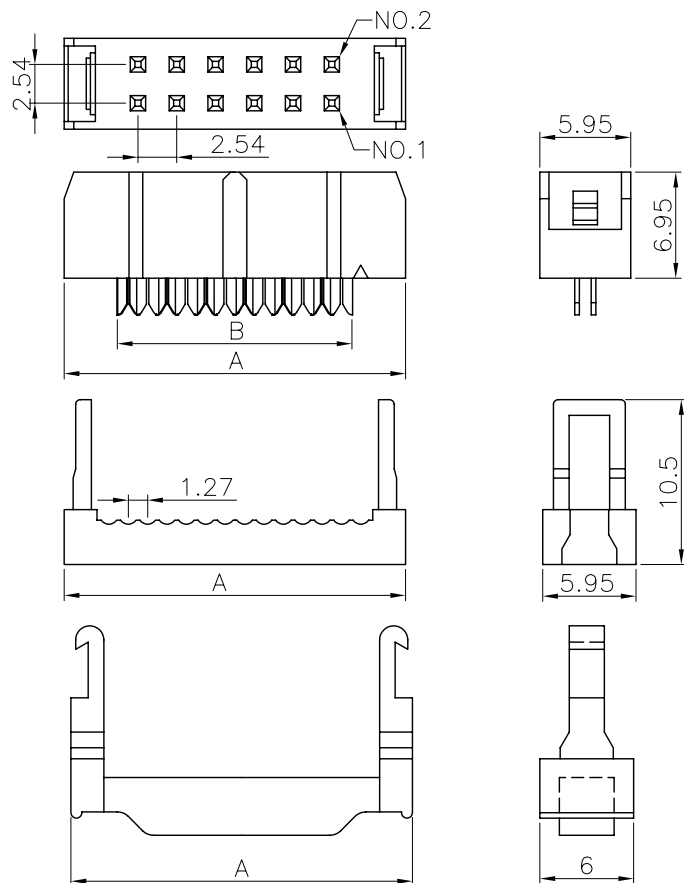

MATERIAL:

INSULATOR : PBT + GLASS FIBER (UL 94V-0)
 CONTACT : COPPER ALLOY
 CONTACT FINISH : GOLD ON MATING END, TIN ON TERMINATION END,
 WITH ENTIRE CONTACT NICKEL UNDERPLATED

SPECIFICATION:

CURRENT RATING : 1A
 DIELECTRIC WITHSTANDING VOLTAGE : 500V AC FOR 1 MINUTE
 INSULATION RESISTANCE : 1000MΩ MIN.
 CONTACT RESISTANCE : 30mΩ MAX.
 OPERATING TEMPERATURE : -55°C ~ +105°C.

Order Information :

SHB61 - 1 2 0 1 1 B 1 0 - R
 1 2 3 4 5 6 7 8 9

1. SERIES NUMBER	SHB61 : 2.54mm PITCH I.D.C. SOCKET
2. POSITION	06 08 10 12 14 16 20 24 26 30 34 36 40 44 50 56 60 62 64
3. CONTACT MATERIAL	0 : COPPER ALLOY 2 : PHOSPHOR BRONZE
4. CONTACT PLATING	1 : SELECTIVE GOLD FLASH 4 : SELECTIVE GOLD 15u" 6 : SELECTIVE GOLD 30u"
5. INSULATOR COLOR	1 :BLACK 8 : GRAY
6. INSULATOR MATERIAL	B : PBT
7. ACCESSORIES	0 : W/O STRAIN RELIEF, W/BAR 1 : W/ STRAIN RELIEF, W/BAR
8. SPECIAL OPTION	0 : STANDARD TYPE
9. GREEN PRODUCT	BLANK : NOT GREEN PRODUCT R : RoHS

CONTACT	A	B	CONTACT	A	B
06	12.18	5.08	30	42.66	35.55
08	14.72	7.62	34	47.74	40.04
10	17.26	10.16	36	50.43	43.18
12	19.80	12.79	40	55.38	48.28
14	22.34	15.24	44	60.64	53.34
16	24.92	17.78	50	68.08	60.96
18	27.42	20.32	55	75.71	66.58
20	29.96	22.66	60	80.90	73.06
24	35.04	27.94	62	83.35	76.20
26	37.58	30.46	64	86.10	78.74

STRAIN RELIEF



維鼎股份有限公司
 WEKANG CO., LTD.
 TEL:886-2-26436301 FAX:886-2-26432714

GENERAL TOLERANCE
 X.X ±0.25
 X.XX ±0.15
 X.XXX ±0.05
 ANGLE TOLERANCE ±1°
 RADIUS ±0.25
 HOLE ±0.13

DRAWN. JEAN
 CHECKED. HENRY
 APPROVED. HENRY

DATE 12 - 09 - 2005
 DATE 12 - 12 - 2005
 DATE 12 - 12 - 2005

DRAWING NO. SHB61-XX0XXB10-R C09012
 TITLE. 2.54mm PITCH I.D.C. SOCKET
 PART NO. SHB61-XX0XXB10-R REV A.0

SIZE A4 UNIT mm SCALE 2/1 SHEET 1 OF 1

REV.	ECN.	DATE	DWN	APVD

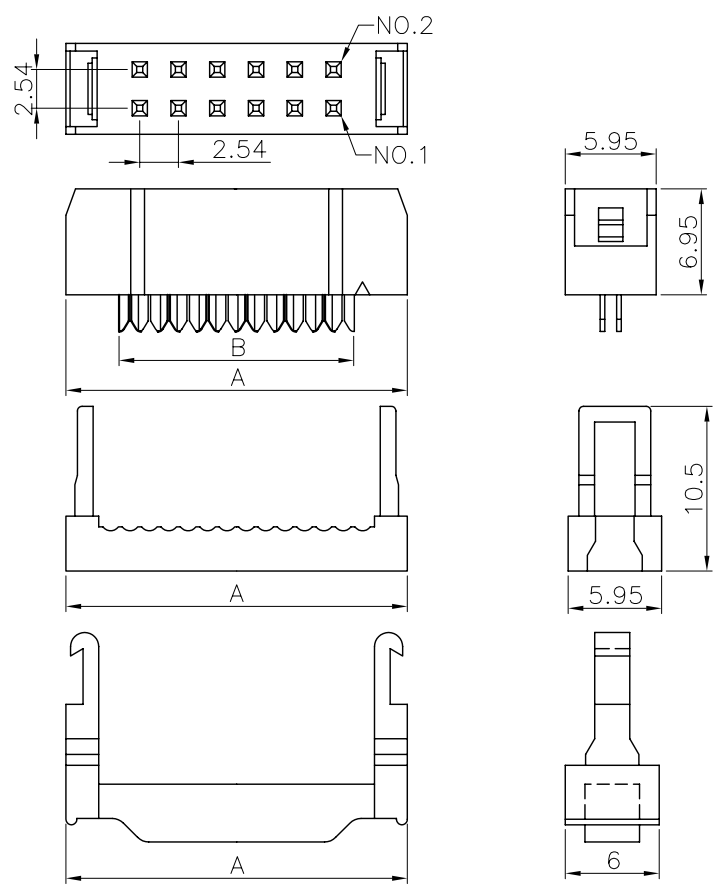

STRAIN RELIEF

POSITION	A	B	POSITION	A	B
06	12.18	05.08	30	42.66	35.55
08	14.72	07.62	34	47.74	40.04
10	17.26	10.16	36	50.43	43.18
12	19.80	12.79	40	55.38	48.28
14	22.34	15.24	44	60.64	53.34
16	24.92	17.78	50	68.08	60.96
18	27.42	20.32	55	75.71	66.58
20	29.96	22.66	60	80.90	73.06
24	35.04	27.94	62	83.35	76.20
26	37.58	30.46	64	86.10	78.74

MATERIAL:

INSULATOR : PBT + GLASS FIBER (UL 94V-0)
 CONTACT : COPPER ALLOY
 CONTACT FINISH : GOLD ON MATING END, TIN ON TERMINATION END,
 WITH ENTIRE CONTACT NICKEL UNDERPLATED

SPECIFICATION:

CURRENT RATING : 1A
 DIELECTRIC WITHSTANDING VOLTAGE : 500V AC FOR 1 MINUTE
 INSULATION RESISTANCE : 1000MΩ MIN.
 CONTACT RESISTANCE : 30mΩ MAX.
 OPERATING TEMPERATURE : -55°C ~ +105°C.

Order Information :

SHB61 - $\frac{1}{1}$ $\frac{2}{2}$ $\frac{0}{3}$ $\frac{1}{4}$ $\frac{1}{5}$ $\frac{B}{6}$ $\frac{3}{7}$ $\frac{0}{8}$ - $\frac{R}{9}$

1. SERIES NUMBER	SHB61 : 2.54mm PITCH I.D.C. SOCKET
2. POSITION	06 08 10 12 14 16 20 24 26 30 34 36 40 44 50 56 60 62 64
3. CONTACT MATERIAL	0 : COPPER ALLOY 2 : PHOSPHOR BRONZE
4. CONTACT PLATING	1 : SELECTIVE GOLD FLASH 4 : SELECTIVE GOLD 15u" 6 : SELECTIVE GOLD 30u"
5. INSULATOR COLOR	1 :BLACK 8 : GRAY
6. INSULATOR MATERIAL	B : PBT
7. ACCESSORIES	2 : W/O STRAIN RELIEF, W/O BAR 3 : W/ STRAIN RELIEF, W/O BAR
8. SPECIAL OPTION	0 : STANDARD TYPE
9. GREEN PRODUCT	BLANK : NOT GREEN PRODUCT R : RoHS

WEKANG CO., LTD.
 維鼎股份有限公司
 TEL:886-2-26436301 FAX:886-2-26432714

SIZE A4	UNIT mm	SCALE 2/1	SHEET 1 OF 1
---------	---------	-----------	--------------

GENERAL TOLERANCE
 X.X ±0.25
 X.XX ±0.15
 X.XXX ±0.05
 ANGLE TOLERANCE ±1°
 RADIUS ±0.25
 HOLE ±0.13

DRAWN. JEAN
 CHECKED. HENRY
 APPROVED. HENRY

DATE 12 - 09 - 2005
 DATE 12 - 12 - 2005
 DATE 12 - 12 - 2005

DRAWING NO. SHB61-XX0XXB30-R C09012
 TITLE. 2.54mm PITCH I.D.C. SOCKET
 PART NO. SHB61-XX0XXB30-R REV A.0