

REV.	ECN.	DATE	DWN	APVD

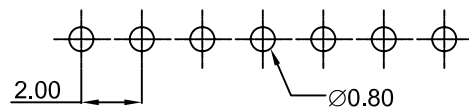
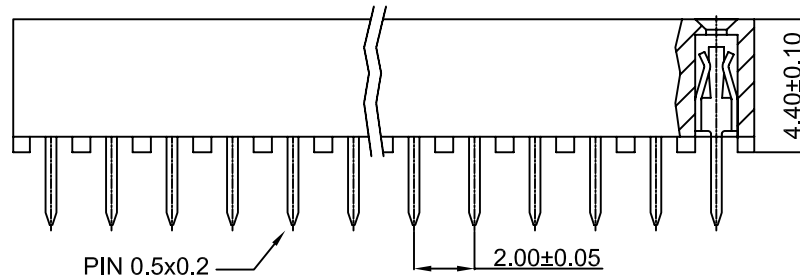
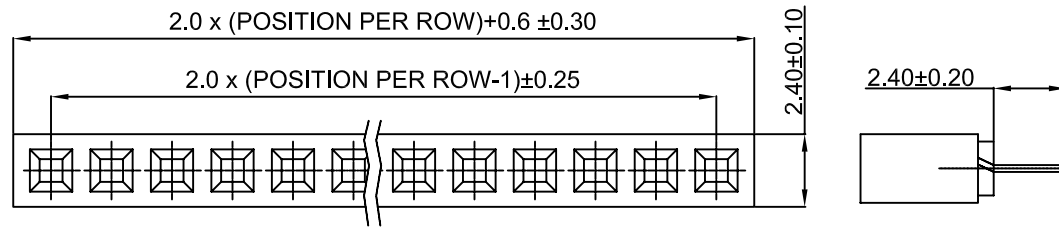

P.C.B LAYOUT

MATERIAL:

INSULATOR : NYLON 6T, UL 94V-0.
 CONTACT : PHOSPHOR BRONZE.
 CONTACT FINISH : GOLD OVER NICKEL.

SPECIFICATION:

CURRENT RATING : 1 AMP.
 DIELECTRIC WITHSTANDING : AC 500V.
 INSULATION RESISTANCE : 5000MΩ MIN.
 CONTACT RESISTANCE : 20mΩ MAX.
 OPERATING TEMPERATURE : -40°C ~ +105°C.

ORDER INFORMATION :

SHD 11 1 - XX 2 A C 1 0 - R
 1 2 3 4 5 6 7 8

- 1. SERIES NUMBER: 7. PIN LENGTH: 1 = 2.4mm
- 2. ROW TYPE: 1= SINGLE ROW 8. GREEN PRODUCT: R=RoHS COMPLIANT
- 3. POSITION PER ROW: 02~04
- 4. CONTACT MATERIAL: 2=PHOSPHOR BRONZE
- 5. CONTACT PLATING: 1 = SELECTIVE GOLD FLASH
 4 = SELECTIVE 15u" GOLD
 6 = SELECTIVE 30u" GOLD
 A = FULL GOLD FLASH
 T = TIN
- 6. INSULATOR MATERIAL: C = NYLON



維鼎股份有限公司
 WEKANG CO., LTD.
 TEL:886-2-26436301 FAX:886-2-26432714

GENERAL TOLERANCE
 XX ± 0.35
 X.XX ± 0.20
 X.XXX ± 0.13
 ANGLE TOLERANCE ± 5°

DRAWN.	CHUNG	DATE	04 - 13 - 2006	DRAWING NO.	SHD111-XX2XC10-R	C12023
CHECKED.	HENRY	DATE	06 - 19 - 2006	TITLE.	2.0mm PITCH FEMALE HEADER, STRAIGHT TYPE PROFILE: 4.4mm	
APPROVED.	HENRY	DATE	06 - 19 - 2006	PART NO.	SHD111-XX2XC10-R	REV A.0

SIZE A4	UNIT mm	SCALE. —	SHEET. 1 OF 1	
------------	------------	-------------	------------------	--

REV.	ECN.	DATE	DWN	APVD

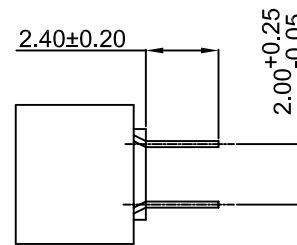
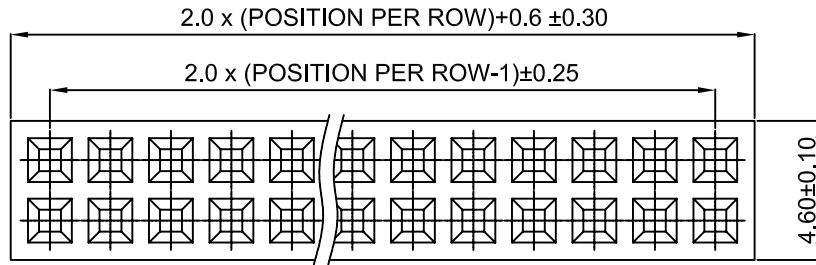

MATERIAL:

INSULATOR : NYLON 6T,UL 94V-0
 CONTACT : PHOSPHOR BRONZE
 CONTACT FINISH : GOLD OVER NICKEL

SPECIFICATION:

CURRENT RATING : 1 AMP
 DIELECTRIC WITHSTANDING : AC 500V
 INSULATION RESISTANCE : 5000 MΩ MIN.
 CONTACT RESISTANCE : 20mΩ MAX.
 OPERATING TEMPERATURE : -40°C ~ +105°C.

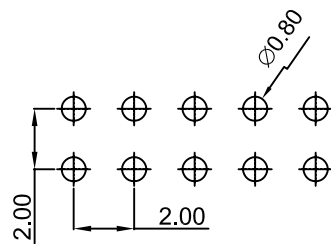
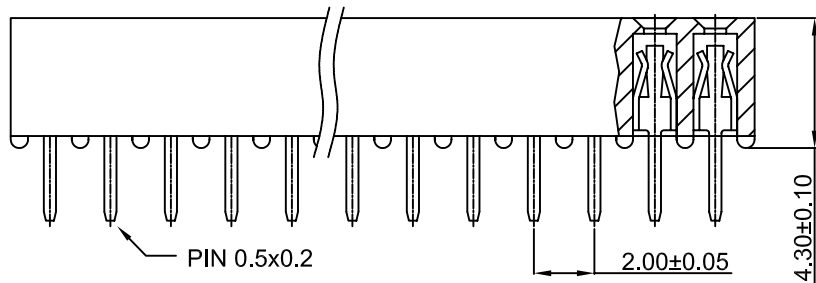

P.C.B LAYOUT

ORDER INFORMATION :

S H D 1 1 2 - X X 2 A C 1 0 - R
 1 2 3 4 5 6 7 8

- | | |
|-------------------------|------------------|
| 1. SERIES NUMBER: | 7. PIN LENGTH: |
| 2. ROW TYPE: | 1=2.4 mm. |
| 2=DUAL ROW | 8. GREEN PRODUT: |
| 3. POSITION PER ROW: | R=RoHS COMPLIANT |
| 02~04 | |
| 4. CONTACT MATERIAL: | |
| 2=PHOSPHOR BRONZE | |
| 5. CONTACT PLATING: | |
| 1= SELECTIVE GOLD FLASH | |
| 4= SELECTIVE 15u" GOLD | |
| 6= SELECTIVE 30u" GOLD | |
| A= FULL GOLD FLASH | |
| T= TIN | |
| 6. INSULATOR MATERIAL: | |
| C=NYLON | |



維鼎股份有限公司
 WEKANG CO., LTD.
 TEL:886-2-26436301 FAX:886-2-26432714

GENERAL TOLERANCE
 X.X ± 0.35
 X.XX ± 0.20
 X.XXX ± 0.13
 ANGLE TOLERANCE ± 5°

DRAWN. CHUNG
 CHECKED. HENRY
 APPROVED. HENRY

DATE 04 - 13 - 2006
 DATE 06 - 19 - 2006
 DATE 06 - 19 - 2006

DRAWING NO. SHD112-XX2XC10-R C12023
 TITLE. 2.0mm PITCH FEMALE HEADER, STRAIGHT
 TYPE PROFILE: 4.3mm
 PART NO. SHD112-XX2XC10-R REV A.0

SIZE A4 UNIT mm SCALE. SHEET. 1 OF 1

REV.	ECN.	DATE	DWN	APVD

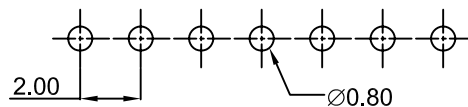
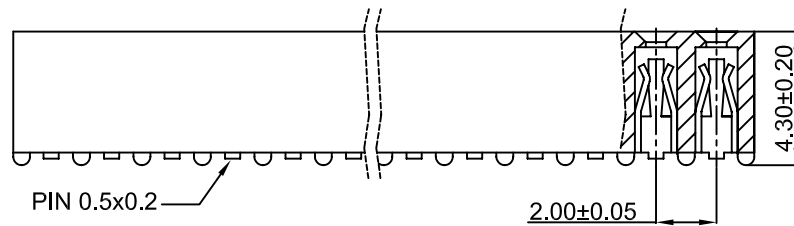
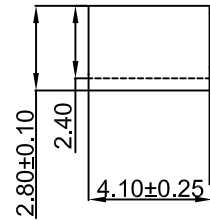
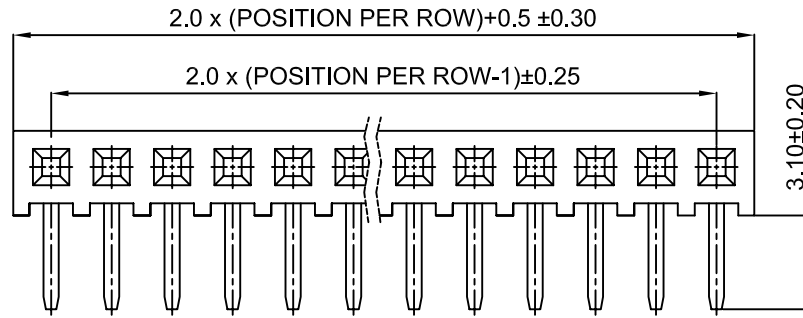

P.C.B LAYOUT

MATERIAL:

INSULATOR : NYLON 6T,UL 94 V-0.
 CONTACT : PHOSPHOR BRONZE.
 CONTACT FINISH : GOLD OVER NICKEL.

SPECIFICATION:

CURRENT RATING : 1 AMP
 DIELECTRIC WITHSTANDING : AC 500V
 INSULATION RESISTANCE : 5000 MΩ MIN.
 CONTACT RESISTANCE : 20mΩ MAX.
 OPERATING TEMPERATURE : -40°C ~ +105°C.

ORDER INFORMATION :

S H D 9 1 1 - X X 2 A C 1 0 - R
 1 2 3 4 5 6 7 8

- | | |
|--|--------------------------------------|
| 1. SERIES NUMBER: | 7. PIN LENGTH:
1=3.1 mm. |
| 2. ROW TYPE:
1= SINGLE ROW | 8. GREEN PRODUT:
R=RoHS COMPLIANT |
| 3. POSITION PER ROW:
02~04 | |
| 4. CONTACT MATERIAL:
2=PHOSPHOR BRONZE | |
| 5. CONTACT PLATING:
1= SELECTIVE GOLD FLASH
4= SELECTIVE 15u" GOLD
6= SELECTIVE 30u" GOLD
A= FULL GOLD FLASH
T= TIN | |
| 6. INSULATOR MATERIAL:
C=NYLON | |



維鼎股份有限公司
 WEKANG CO., LTD.
 TEL:886-2-26436301 FAX:886-2-26432714

GENERAL TOLERANCE
 X.X ± 0.35
 X.XX ± 0.20
 X.XXX ± 0.13
 ANGLE TOLERANCE ± 5°

DRAWN. CHUNG
 CHECKED. HENRY
 APPROVED. HENRY

DATE 04 - 13 - 2006
 DATE 06 - 19 - 2006
 DATE 06 - 19 - 2006

DRAWING NO. SHD911-XX2XC10-R C12023
 TITLE. 2.0mm PITCH FEMALE HEADER, RIGHT ANGLE TYPE
 PART NO. SHD911-XX2XC10-R REV A.0

SIZE A4	UNIT mm	SCALE. —	SHEET. 1 OF 1	
------------	------------	-------------	------------------	--

REV.	ECN.	DATE	DWN	APVD

MATERIAL:

INSULATOR : NYLON 6T,UL 94 V-0.
 CONTACT : PHOSPHOR BRONZE.
 CONTACT FINISH : GOLD OVER NICKEL.

SPECIFICATION:

CURRENT RATING : 1 AMP.
 DIELECTRIC WITHSTANDING : AC 500V .
 INSULATION RESISTANCE : 5000 MΩ MIN.
 CONTACT RESISTANCE : 20mΩ MAX.
 OPERATING TEMPERATURE : -40°C ~ +105°C.

ORDER INFORMATION :

S H D 9 1 2 - X X 2 A C 1 0 - R
 1 2 3 4 5 6 7 8

- | | |
|--|-------------------------------------|
| 1. SERIES NUMBER:
2. ROW TYPE:
2=DUAL ROW | 7. PIN LENGHT:
1=3.0 mm. |
| 3. POSITION PER ROW:
02~04 | 8. GREEN PRDUT:
R=RoHS COMPLIANT |
| 4. CONTACT MATERIAL:
2=PHOSPHOR BRONZE | |
| 5. CONTACT PLATING:
1= SELECTIVE GOLD FLASH
4= SELECTIVE 15u" GOLD
6= SELECTIVE 30u" GOLD
A= FULL GOLD FLASH
T= TIN | |
| 6. INSULATOR MATERIAL:
C=NYLON | |

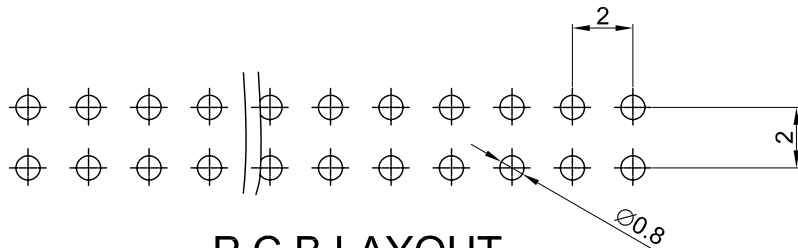
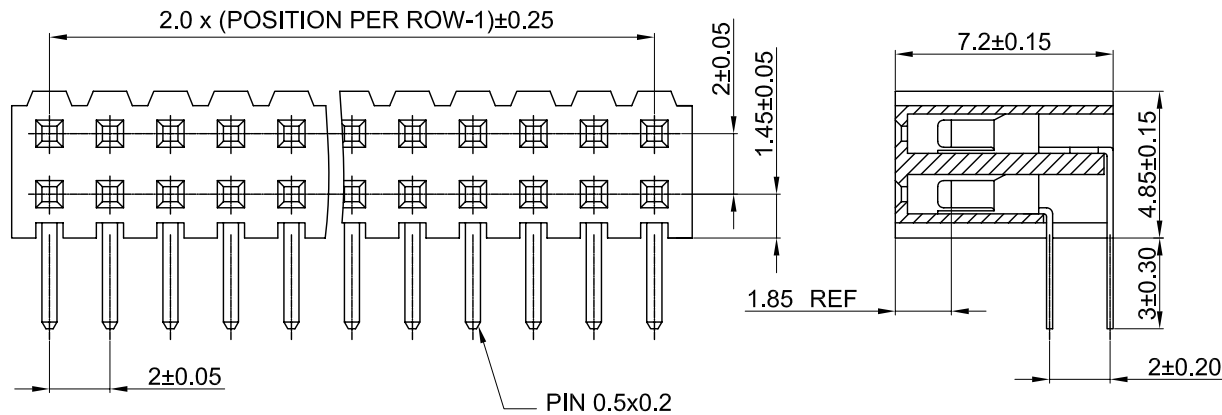
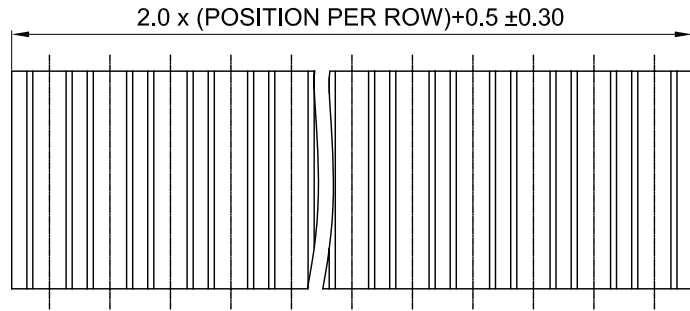

P.C.B LAYOUT

 維鼎股份有限公司 WEKANG CO., LTD. TEL:886-2-26436301 FAX:886-2-26432714				
SIZE A4	UNIT mm	SCALE —	SHEET 1 OF 1	

GENERAL TOLERANCE
 X.X ± 0.35
 X.XX ± 0.20
 X.XXX ± 0.13
 ANGLE TOLERANCE ± 5°

DRAWN.	CHUNG	DATE	04 - 13 - 2006
CHECKED.	HENRY	DATE	06 - 19 - 2006
APPROVED.	HENRY	DATE	06 - 19 - 2006

DRAWING NO.	SHD912-XX2XC10-R	C12023
TITLE.	2.0mm PITCH FEMALE HEADER, RIGHT ANGLE TYPE	
PART NO.	SHD912-XX2XC10-R	REV A.0